

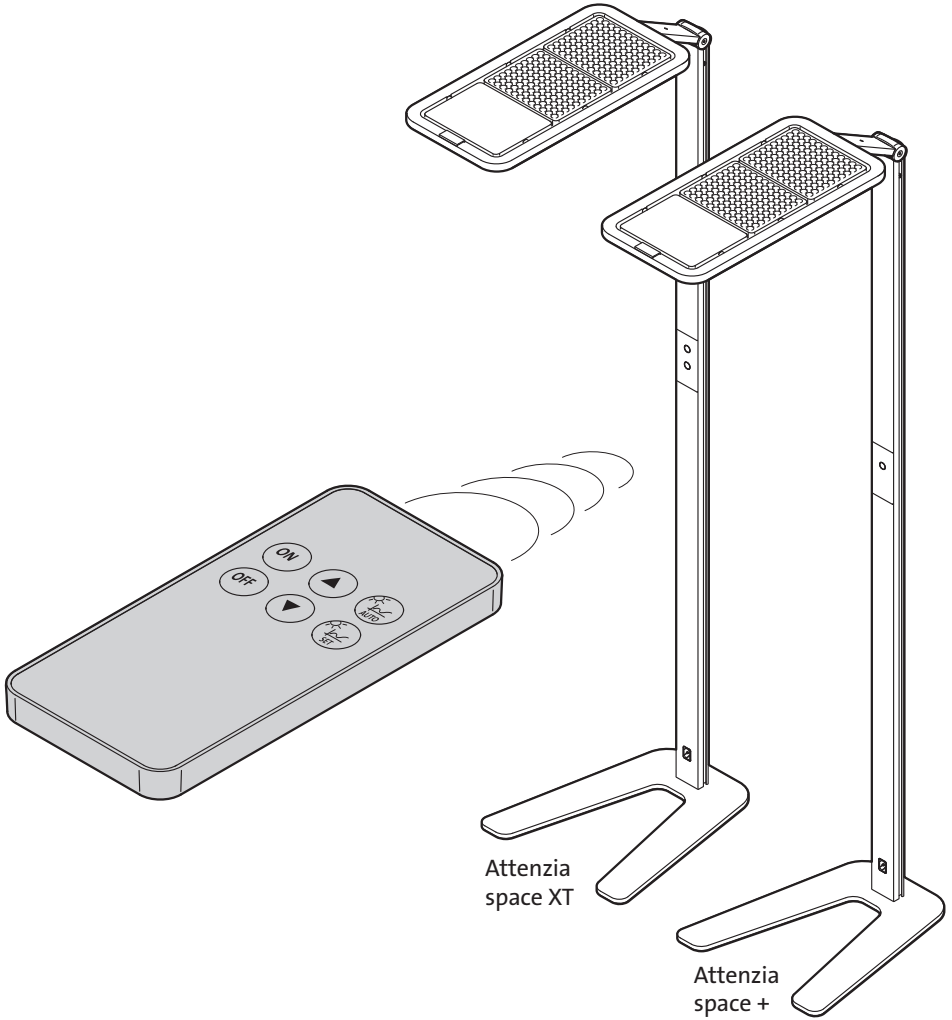

NOVUS® Attenzia Space Remote Control

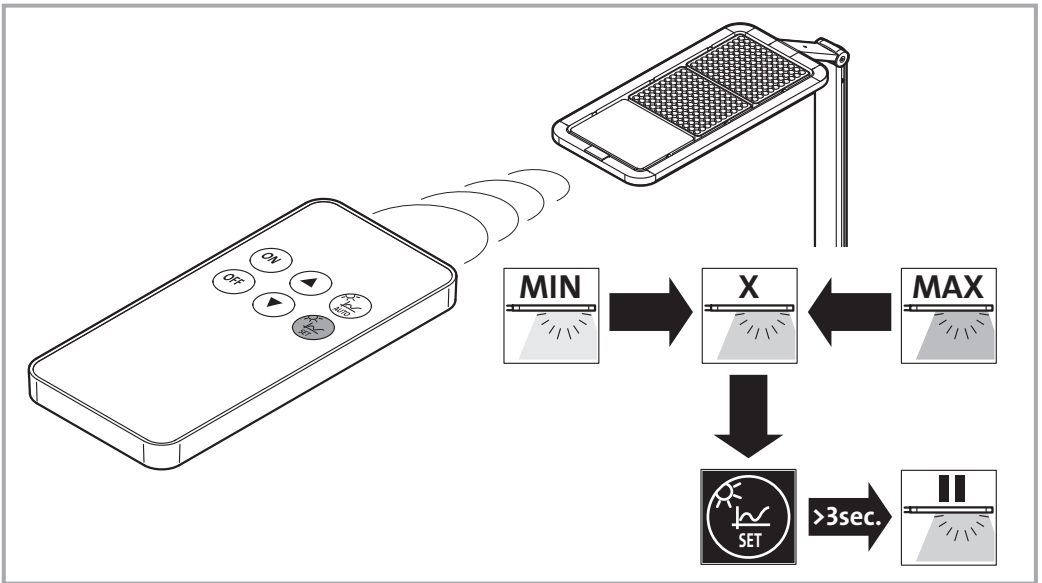

DE	Originalgebrauchsanleitung	4
EN	Translation of the original operating instructions.....	4, 6
FR	Traduction de la version originale du mode d'emploi	4, 7
NL	Vertaling van de originele handleiding	4, 8
IT	Traduzione delle istruzioni per l'uso originali	4, 9
ES	Traducción de las instrucciones originales para el servicio	4, 10
PT	Tradução do manual de instruções original	4, 11
PL	Tłumaczenie oryginalnej instrukcji obsługi.....	4, 12
CS	Překlad originálního návodu k obsluze.....	4, 13
BG	Оригинално ръководство за експлоатация	4, 14
RO	Traducere a instrucțiunilor de utilizare originale.....	4, 15
RU	Перевод оригинального руководства по эксплуатации	4, 16
EL	Μετάφραση του πρωτοτύπου οδηγιών λειτουργίας.....	4, 17
AR	4, 18	ترجمة تعليمات الاستعمال الأصلية

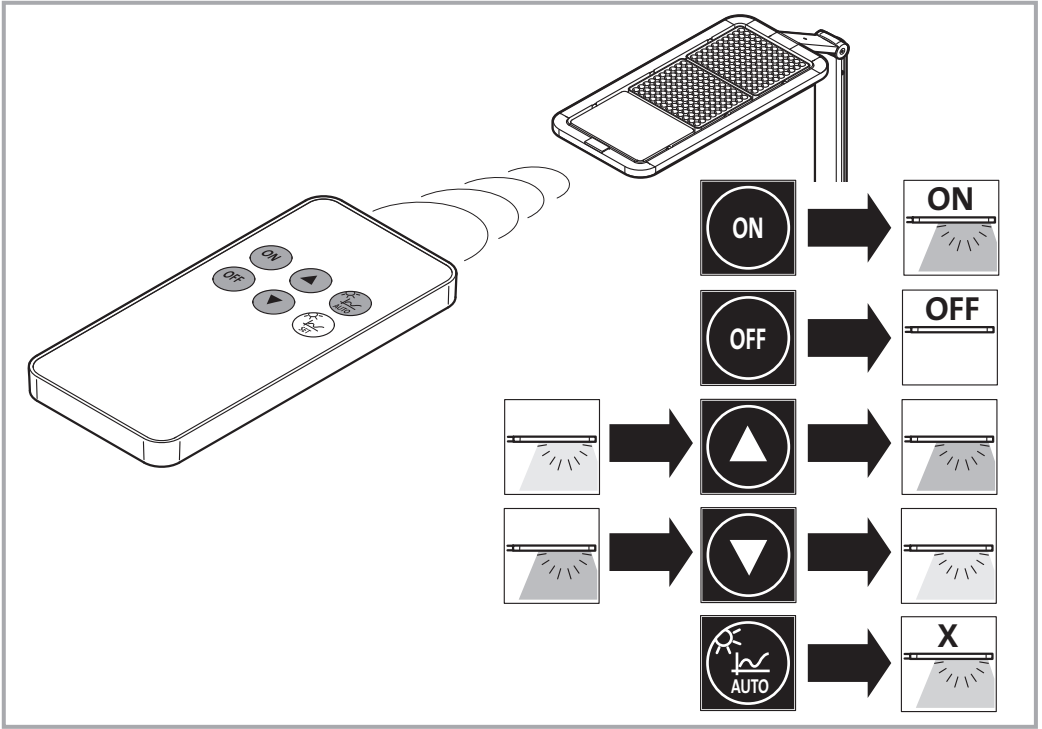

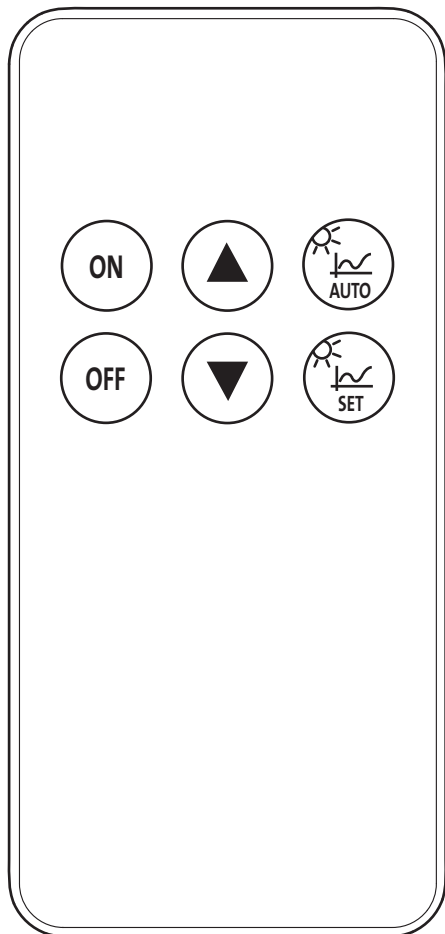

DE Piktogrammlegende



Einschalten der Leuchten



Ausschalten der Leuchten



Aktuellen Dimmlevel erhöhen



Aktuellen Dimmlevel vermindern



Speichern der Helligkeitseinstellung
(3 Sekunden gedrückt halten)



Einschalten der Konstantlichtregelung



geringe Helligkeitseinstellung



hohe Helligkeitseinstellung



gewählte Helligkeitseinstellung



Helligkeitseinstellung gespeichert

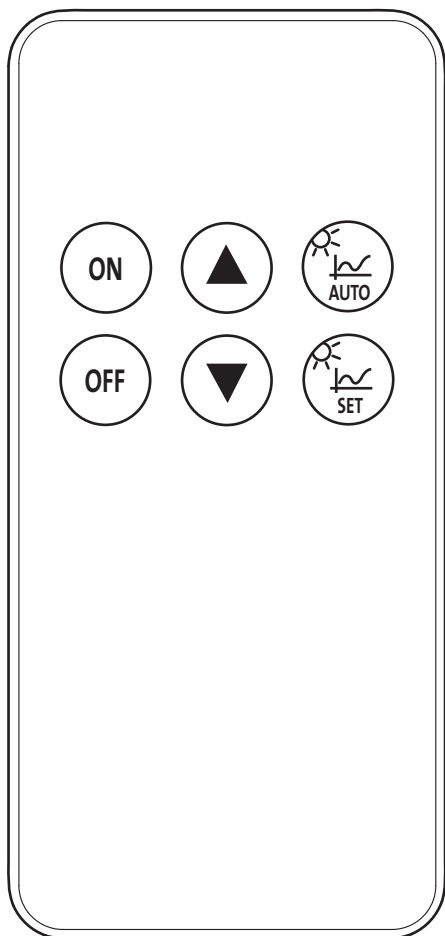

EN Key to pictograms



Switch on the lights



Switch off the lights



Increase the current dimming level



Reduce the current dimming level



Save the brightness setting
(press and hold for 3 seconds)



Switch on constant light control



Low brightness setting



High brightness setting



Selected brightness setting



Brightness setting saved

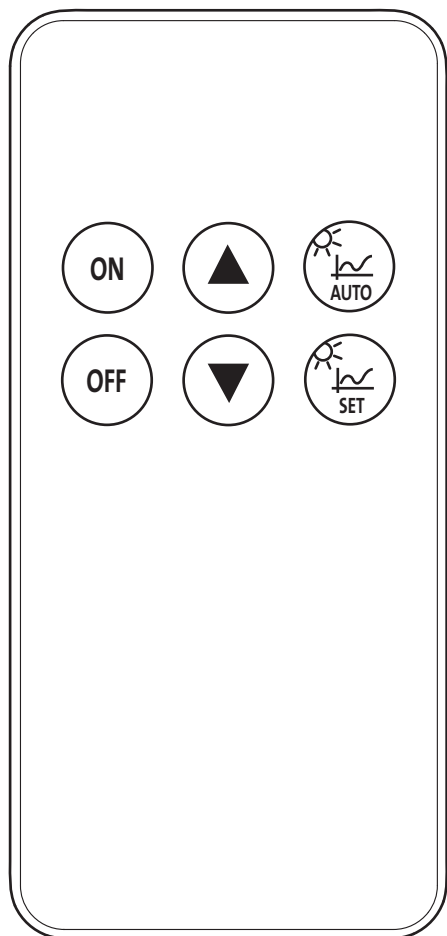

FR Légende des pictogrammes



Allumage de la lampe



Extinction de la lampe



Augmenter la valeur de gradation actuelle



Réduire la valeur de gradation actuelle



Sauvegarde du réglage de luminosité (maintenir appuyé 3 secondes)



Allumage de la régulation à lumière constante



Réglage de luminosité faible



Réglage de luminosité élevé



Réglage de luminosité sélectionné



Réglage de luminosité sauvegardé

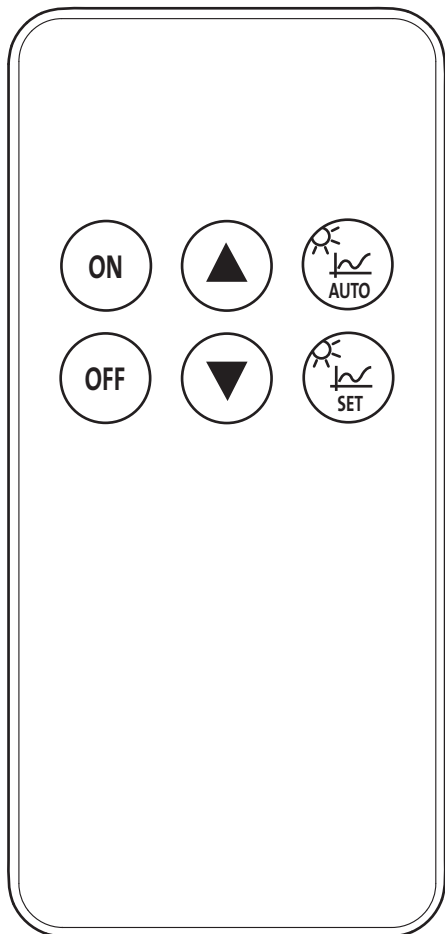

NL Legenda van pictogrammen



Inschakelen van de verlichting



Uitschakelen van de verlichting



Actueel dimniveau verhogen



Actueel dimniveau verlagen



De helderheidsinstelling opslaan
(3 seconden ingedrukt houden)



Inschakelen van de constante verlichting



lage helderheidsinstelling



hoge helderheidsinstelling



geselecteerde helderheidsinstelling



helderheidsinstelling opgeslagen

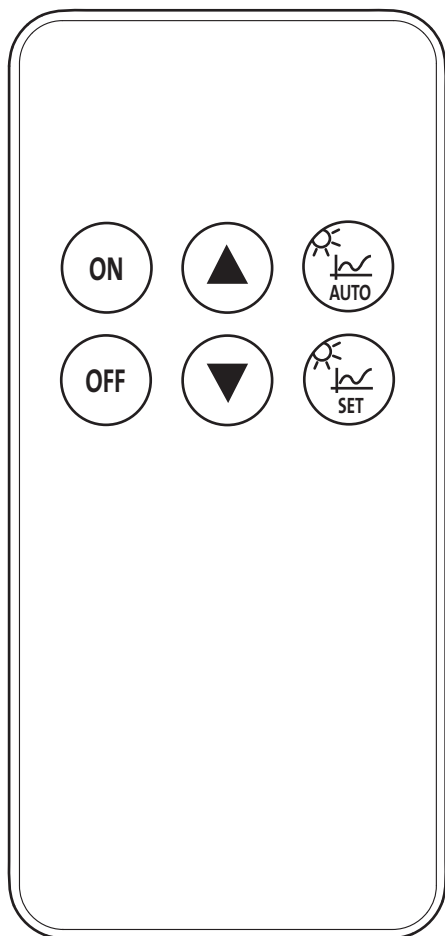

IT Legenda pittogrammi



Accendere le lampade



Spegnere le lampade



Aumentare il livello di dimmerazione attuale



Diminuire il livello di dimmerazione attuale



Salvare l'impostazione della luminosità (tenere premuto per 3 secondi)



Accendere la regolazione della luce costante



Impostazione bassa della luminosità



Impostazione alta della luminosità



Impostazione della luminosità selezionata



Impostazione della luminosità salvata

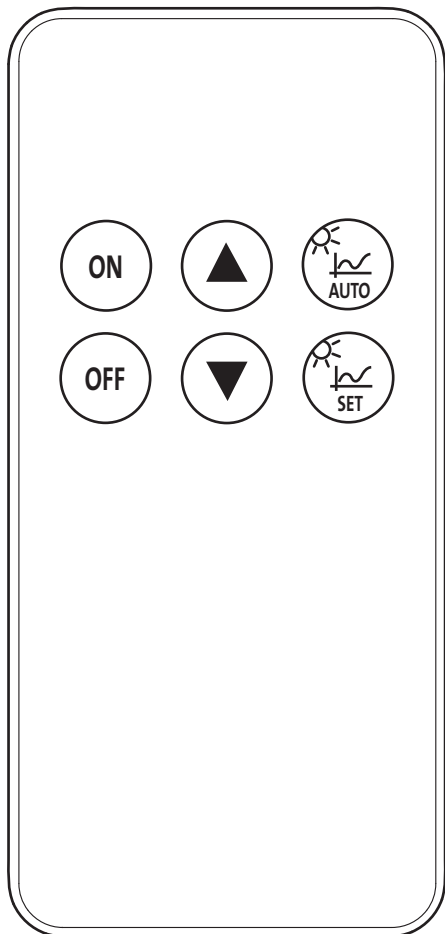

ES Significado de los pictogramas



Encendido de la lámpara



Apagado de la lámpara



Aumentar el nivel actual de atenuación



Reducir el nivel actual de atenuación



Guardar el ajuste de luminosidad (mantener pulsado durante 3 segundos)



Encender la regulación de luz constante



Ajuste de luminosidad bajo



Ajuste de luminosidad alto



Ajuste de luminosidad seleccionado



Ajuste de luminosidad guardado

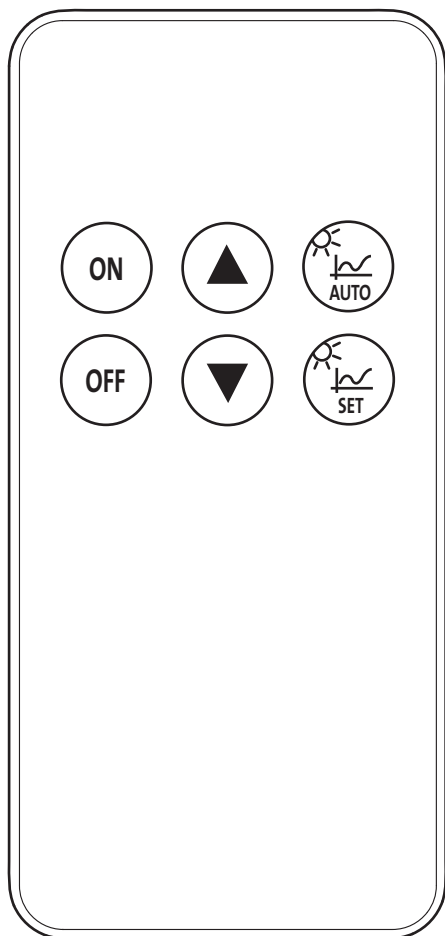

PT Legenda dos pictogramas



Ligar as lâmpadas



Desligar as lâmpadas



Aumentar nível de intensidade luminosa atual



Diminuir nível de intensidade luminosa atual



Guardar ajuste da luminosidade (manter premido durante 3 segundos)



Ligar a regulação de luz constante



Ajuste reduzido da luminosidade



Ajuste elevado da luminosidade



Ajuste de luminosidade selecionado



Ajuste de luminosidade guardado

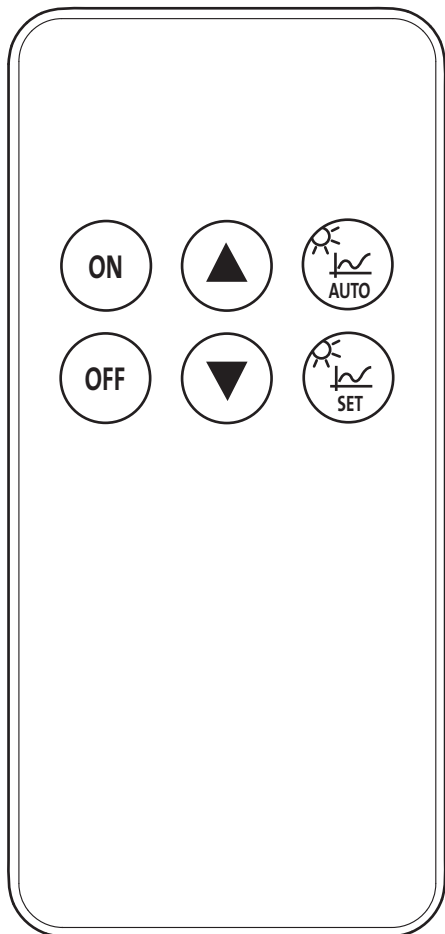

PL **Objaśnienie symboli**



włączanie lamp



wyłączanie lamp



zwiększanie aktualnego poziomu przyciemnienia



zmniejszanie aktualnego poziomu przyciemnienia



zapisywanie ustawienia jasności (przytrzymać przez 3 sekundy)



włączanie regulacji światła stałego



niskie ustawienie jasności



wysokie ustawienie jasności



wybrane ustawienie jasności



zapisano ustawienie jasności

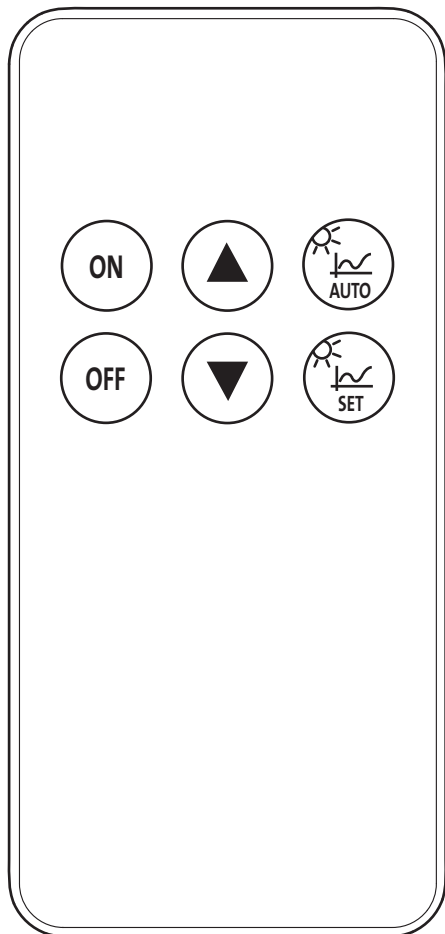

CS Popis piktogramů



Zapnutí svítidel



Vypnutí svítidel



Zvýšení současné úrovně ztlumení



Snižení současné úrovně ztlumení



Uložit nastavení jasu
(přidržit stisknuté 3 sekundy)



Zapnutí konstantní regulace světla



nízké nastavení jasu



vysoké nastavení jasu



zvolené nastavení jasu



nastavení jasu uloženo

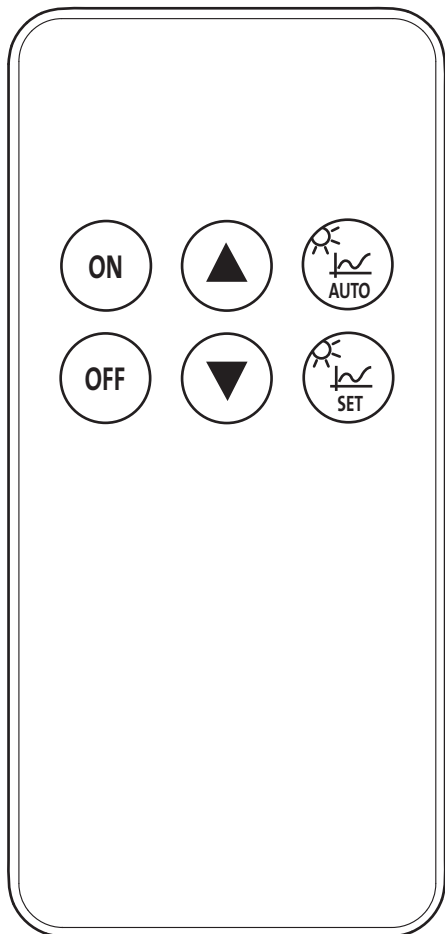

BG Легенда на пиктограмите



Включване на лампите



Изключване на лампите



Увеличаване на актуалното ниво на димиране



Намаляване на актуалното ниво на димиране



Съхраняване на настройката на яркостта (задържане натиснато за 3 секунди)



Включване на регулирането на константната светлина



ниска настройка на яркостта



висока настройка на яркостта



избрана настройка на яркостта



съхранена настройка на яркостта

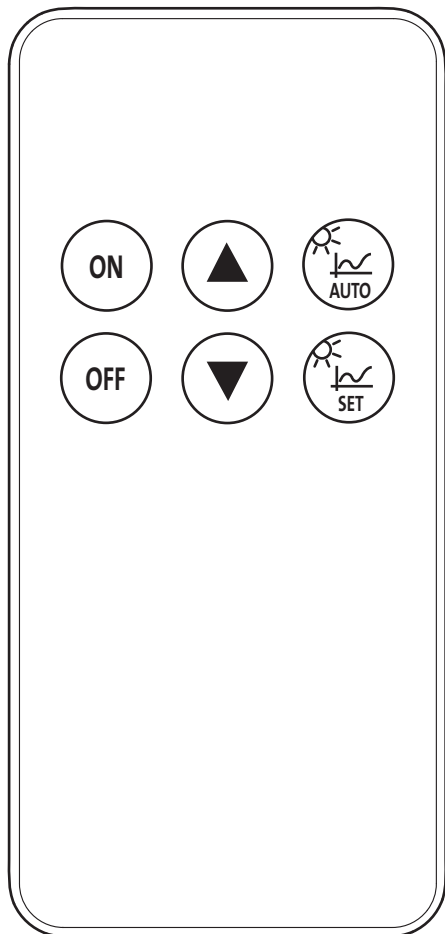

RO Legenda pictogramelor



Cuplarea corpurilor de iluminat



Decuplarea corpurilor de iluminat



Creșterea nivelului actual de scădere a intensității



Reducerea nivelului actual de scădere a intensității



Salvarea setării de luminozitate (țineți apăsat timp de 3 secunde)



Cuplarea reglării de lumină constantă



Setare de luminozitate redusă



Setare de luminozitate ridicată



Setare de luminozitate selectată



Setare de luminozitate salvată

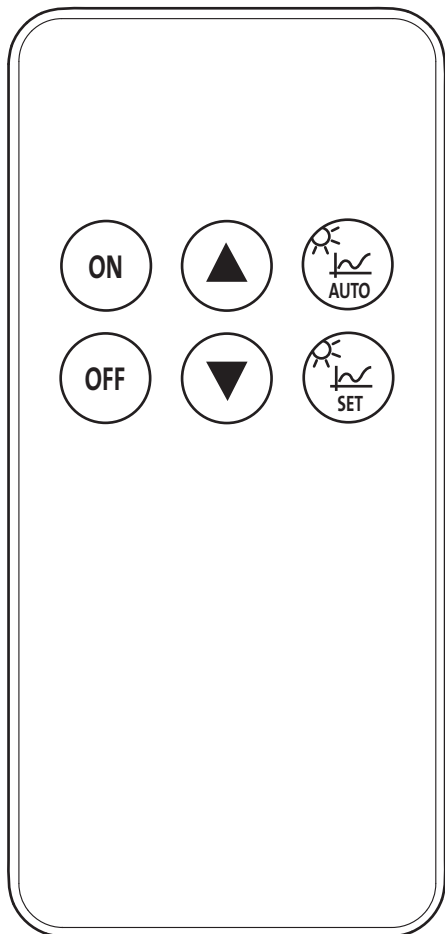

RU Объяснение пиктограмм



Включение светильника



Выключение светильника



Усиление текущего уровня подсветки



Уменьшение текущего уровня подсветки



Сохранение настроек яркости (нажать и удерживать 3 секунды)



Включение режима регулирования постоянного света



низкая настройка яркости



высокая настройка яркости



выбранная настройка яркости



настройка яркости сохранена

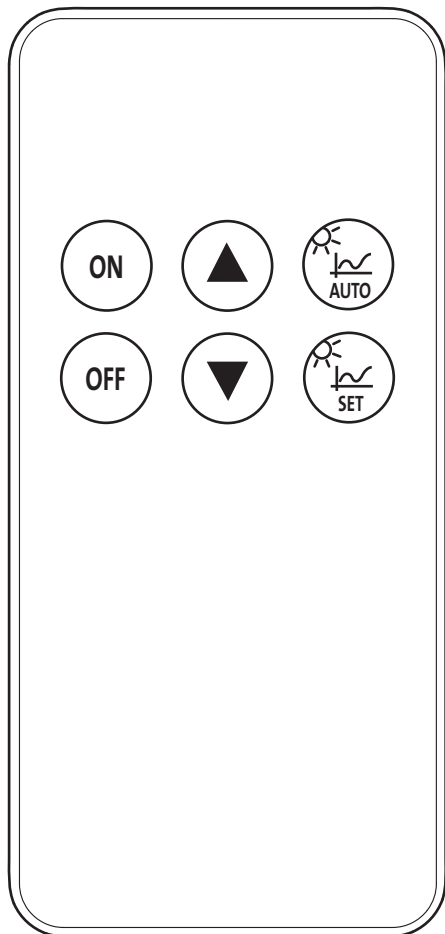

EL Λεζάντες εικονογραμμάτων



Ενεργοποίηση των φωτιστικών σωμάτων



Απενεργοποίηση των φωτιστικών σωμάτων



Αύξηση τρέχ. επιπέδου ρεοστατ. ρύθμισης



Μείωση τρέχ. επιπέδου ρεοστατ. ρύθμισης



Αποθήκευση της ρύθμισης φωτεινότητας (κρατήστε πατημένο για 3 δευτερόλεπτα)



Ενεργοποίηση της ρύθμισης σταθερού φωτισμού



Ρύθμιση χαμηλής φωτεινότητας



Ρύθμιση υψηλής φωτεινότητας



Επιλεγμένη ρύθμιση φωτεινότητας



Ρύθμιση φωτεινότητας αποθηκευμένη

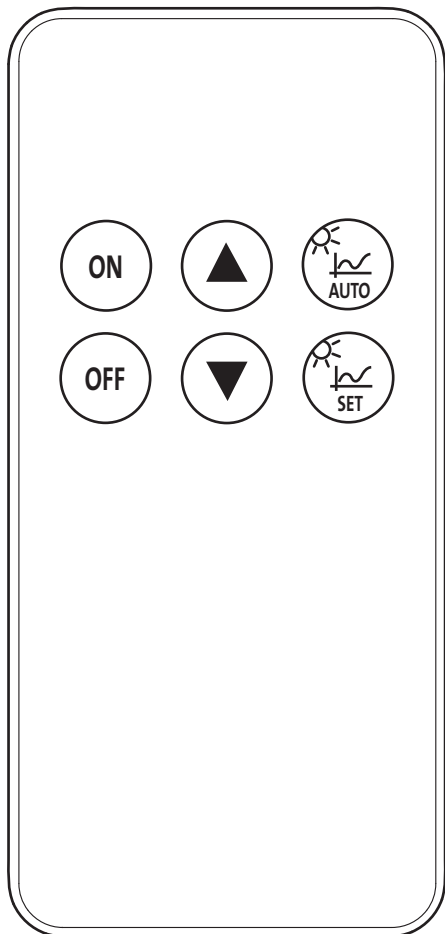

رموز الرسومات

AR

تشغيل المصابيح

ON

إيقاف المصابيح

OFF

زيادة مستوى التعتيم الحالي

▲

تقليل مستوى التعتيم الحالي

▼

حفظ مستوى السطوع (الضغط باستمرار لمدة 3 ثوان)

☀️
SET

تشغيل وحدة التحكم في الإضاءة المستمرة

☀️
AUTO

مستوى سطوع منخفض



مستوى سطوع عالٍ



مستوى السطوع المختار

X



تم حفظ مستوى السطوع



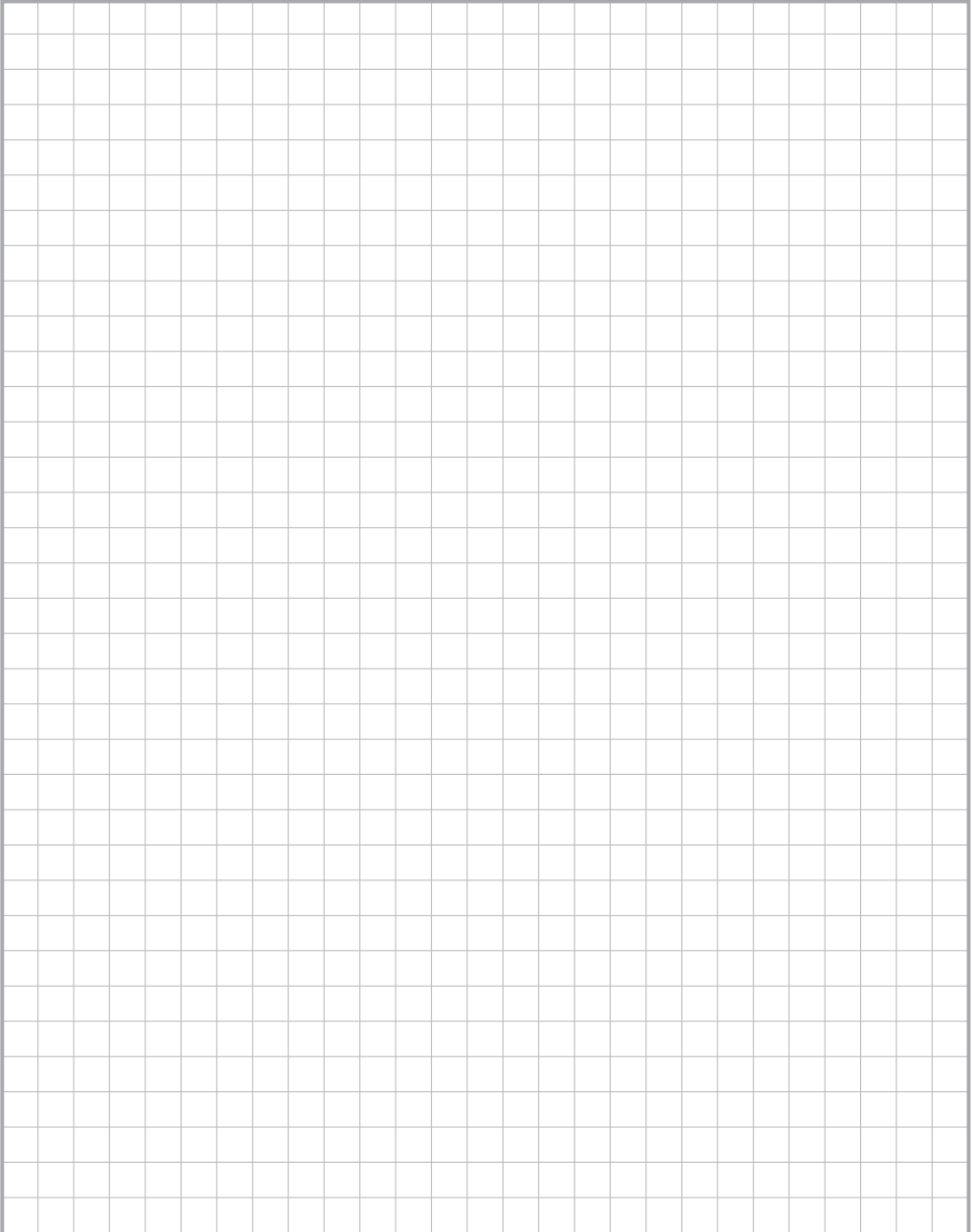

Headquarters:

Novus Dahle GmbH & Co. KG
Breslauer Straße 34-38
49808 Lingen
Germany

Service contact:

Novus Dahle GmbH & Co. KG
Hessenweg 53
49811 Lingen
Germany
Tel.: +49 (0) 591 9140-457
Fax: +49 (0) 591 9140-841
E-Mail: info@novus.de
Web: www.novus.de

© Copyright 2018 by Novus Dahle GmbH & Co. KG

NOVUS[®]
www.novus.de